

# ISA 666 Internet Security Protocols

## Basic Number Theory Hash Functions

ISA 666

Duminda Wijesekera

1

## Basic Number Theory

- We are talking about integers!
  - Integers have many interesting properties that have been widely used in modern cryptography
  - Wonder how to manually calculate
    - $101^{115} \bmod 33?$
    - $115^{101} \bmod 33?$
- Divisor
  - We say that  $b \neq 0$  divides  $a$  if  $a = mb$  for some  $m$ , denoted  $b|a$ .  $b$  is a divisor of  $a$ .
  - If  $a|1$ , then  $a = 1$  or  $-1$ .
  - If  $a|b$  and  $b|a$ , then  $a = b$  or  $-b$ .
  - Any  $b \neq 0$  divides  $0$ .
  - If  $b|g$  and  $b|h$ , then  $b|(mg+nh)$  for arbitrary integers  $m$  and  $n$ .

ISE at George Mason University

ISA 666 Duminda Wijesekera

2

## Prime Numbers

- Prime numbers
  - An integer  $p > 1$  is a prime number if its only divisors are  $1$ ,  $-1$ ,  $p$ , and  $-p$ .
  - Examples:  $2, 3, 5, 7, 11, 13, 17, 19, 31, \dots$

**Theorem:** There are infinitely many prime numbers

**Proof:** Suppose there are only finitely many, say  $n$  many and the primes are  $p_1, \dots, p_n$ . Then  $1 + p_1 \times \dots \times p_n$  is not divisible by either of  $p_1, \dots, p_n$ .  $\square$

ISE at George Mason University

ISA 666 Duminda Wijesekera

3

## Factorization

- Any integer  $a > 1$  can be factored in a unique way as
  - where each  $p_1 > p_2 > \dots > p_t$  are prime numbers and where each  $a_i > 0$ .
  - Examples:  $91 = 13 \times 7$ ,  $11011 = 13 \times 11^2 \times 7$ .
- The general expression is of the form:  
where each  $p_i$  is a prime.

$$a = p_1^{a_1} p_2^{a_2} \dots p_t^{a_t}$$

ISE at George Mason University

ISA 666 Duminda Wijesekera

4

## Factorization of Numbers

- Another view of  $a|b$ :
  - Let  $P$  be the set of all prime numbers
  - Represent  $a$  as  $a = \prod_{p \in P} p^{a_p}$ , where  $a_p \geq 0$ .
  - Represent  $b$  as  $b = \prod_{p \in P} p^{b_p}$ , where  $b_p \geq 0$ .
  - $a|b$  means that  $a_i \leq b_i$ .
- Factoring an integer
  - Not trivial for large, say 128 bit, integers!
  - The very foundation of RSA security

ISE at George Mason University

ISA 666 Duminda Wijesekera

5

## Basic Number Theory (Cont'd)

- Greatest common divisor:  $\gcd(a, b)$ 
  - $\gcd(a, b) = \max \{k \mid k|a \text{ and } k|b\}$
  - Examples
    - $\gcd(6, 15) = 3$ .
    - $\gcd(60, 24) = \gcd(60, -24) = 12$ .
    - $\gcd(a, 0) = a$ .
  - $\gcd(a, b)$  can be easily derived if we can factor  $a$  and  $b$ .
- Relatively Prime Numbers
  - Integers  $a$  and  $b$  are relatively prime iff  $\gcd(a, b) = 1$ .
  - Non-prime numbers can be relative primes!
  - Example:  $8$  and  $15$  are relatively prime.

ISE at George Mason University

ISA 666 Duminda Wijesekera

6

## How To Find Greatest Common Divisor? Euclid's Algorithm

- Observation
  - $\gcd(a, b) = \gcd(b, a - b)$
  - $\gcd(a, b) = \gcd(b, a \bmod b)$
- Euclid  $(d, f)$ ,  $d > f > 0$ .
  - $X \leftarrow d; Y \leftarrow f$
  - While  $Y \neq 0$  do
    - $R = X \bmod Y$
    - $X \leftarrow Y$
    - $Y \leftarrow R$
  - return  $X = \gcd(d, f)$

Example:  $\gcd(12, 9)$   
First Round  
 •  $x=12, y=9$   
 •  $R = 12 \bmod 9 = 3$   
Second Round  
 •  $x=9, y=3$   
 •  $R = 9 \bmod 3 = 0$   
Third round ( $y=0$ )  
 Return (3)

## Modulo Operator

- Given any positive integer  $n$  and any integer  $a$ , we have  $a = qn + r$ , where  $0 \leq r < n$  and  $q = \lfloor a/n \rfloor$ .
  - We write  $r = a \bmod n$ .
  - The remainder  $r$  is often referred to as a residue.
  - Example:
    - $2 = 12 \bmod 5$ .
- Two integer  $a$  and  $b$  are said to be **congruent modulo  $n$**  if  $a \bmod n = b \bmod n$ .
  - We write  $a \equiv b \pmod n$
  - Example:
    - $7 \equiv 12 \pmod 5$ .

## Modulo Operator (Cont'd)

- Properties of the modulo operator
  - $a \equiv b \pmod n$  iff  $a$  differs  $b$  by multiple of  $n$ .
  - $a \equiv b \pmod n$  iff  $n \mid (a - b)$
  - $a \equiv b \pmod n$  implies  $b \equiv a \pmod n$ .
  - $a \equiv b \pmod n$  and  $b \equiv c \pmod n$  imply  $a \equiv c \pmod n$ .

## Modular Arithmetic

- Observation:
  - The  $(\bmod n)$  operator maps all integers into the set of integers  $\{0, 1, 2, \dots, (n-1)\}$ . Creates a partition on the integer set
- Modular addition.
  - $[(a \bmod n) + (b \bmod n)] \bmod n = (a+b) \bmod n$
- Modular subtraction.
  - $[(a \bmod n) - (b \bmod n)] \bmod n = (a - b) \bmod n$
- Modular multiplication.
  - $[(a \bmod n) \times (b \bmod n)] \bmod n = (a \times b) \bmod n$

## An Exercise ( $n=5$ )

- Addition
- Multiplication

	0	1	2	3	4
0					
1					
2					
3					
4					

	0	1	2	3	4
0					
1					
2					
3					
4					

Exponentiation  
 $92^{10} \bmod 5 = \underline{\hspace{2cm}}$

## Properties of Modular Arithmetic

- $Z_n = \{0, 1, \dots, (n-1)\}$
- Commutative laws
  - $(w + x) \bmod n = (x + w) \bmod n$
  - $(w \times x) \bmod n = (x \times w) \bmod n$
- Associative laws
  - $(w + x) + y \bmod n = [w + (x + y)] \bmod n$
  - $(w \times x) \times y \bmod n = [w \times (x \times y)] \bmod n$
- Distributive law
  - $[w \times (x + y)] \bmod n = [(w \times x) + (w \times y)] \bmod n$
- Identities
  - $(0 + w) \bmod n = w \bmod n$
  - $(1 \times w) \bmod n = w \bmod n$
- Additive inverse ( $-w$ )
  - For each  $w \in Z_n$ , there exists a  $z$  such that  $w + z = 0 \bmod n$ .

## Modular Multiplicative Inverse

- Why do we care about modular multiplicative inverse?
  - Used in RSA...
- Don't always exist
  - Example: There doesn't exist a  $z$  such that  $6 \times z = 1 \pmod 8$ .

$Z_8$	0	1	2	3	4	5	6	7
$\times 6$	0	6	12	18	24	30	36	42
Residues	0	6	4	2	0	6	4	2

- An integer  $a \in Z_n$  has a modular multiplicative inverse iff  $\gcd(a, n) = 1$ .
- In particular, if  $n$  is a prime number, then all elements in  $Z_n$  have modular multiplicative inverse.

## Extended Euclid Algorithm:

Computing modular inverses:  $Y2 = d^{-1} \pmod f$

### Extended Euclid (d, f)

- $(X1, X2, X3) \leftarrow (1, 0, f)$ ;
- $(Y1, Y2, Y3) \leftarrow (0, 1, d)$
- If  $Y3 = 0$ 
  - return ("no inverse")
- If  $Y3 = 1$ 
  - return  $(Y2) /* = d^{-1} \pmod f */$
- $Q = \lfloor X3/Y3 \rfloor$
- $(T1, T2, T3) \leftarrow (X1 - QY1, X2 - QY2, X3 - QY3)$
- $(X1, X2, X3) \leftarrow (Y1, Y2, Y3)$
- $(Y1, Y2, Y3) \leftarrow (T1, T2, T3)$
- Goto 2

### Compute $5^{-1} \pmod 6$

- $(x1, x2, x3) = (1, 0, 6)$
  - $(y1, y2, y3) = (0, 1, 5)$
  - 3, 4 no effect
  - $q = \lfloor 6/5 \rfloor = 1$
  - $(T1, T2, T3) = (5, 5, 1)$
  - $(x1, x2, x3) = (0, 1, 5)$
  - $(y1, y2, y3) = (5, 5, 1)$
  9. Goto 2
  - $(y1, y2, y3) = (5, 5, 1)$
  3. no effect
  - return  $(y2) = 5$
- NOTE:  $5 \cdot 5 = 25 = 1 \pmod 6$**

## Observations

In the previous Algorithm:

$$fX1 + dX2 = X3; fY1 + dY2 = Y3 \text{ -- loop invariants}$$

If  $Y3 = 1$ , then  $fY1 + dY2 = 1$  and therefore  $Y2 = d^{-1} \pmod f$

(also  $Y1 = f^{-1} \pmod d$ )

## Chinese Remainder Theorem

- If  $z_1, \dots, z_n$  are relatively prime to each other, and for some (unknown) number  $y$ ,  $y \pmod{z_i} = x_i$  ( $i=1, \dots, n$ ), then  $y \pmod{z_1 z_2 \dots z_n}$  can be determined by  $z_1, \dots, z_n$  without knowing  $y$ .
- In other words, there are two equivalent representations of a modulo number
  - $y \pmod{z_1 z_2 \dots z_n}$  ( $z_1, \dots, z_n$  are relatively prime)
  - $y \pmod{z_1}, \dots, y \pmod{z_n}$ .
- Relates the modulo operation with factorization

## Chinese Remainder Theorem

- Two simultaneous congruences  $X = n_1 \pmod{m_1}$  and  $X = n_2 \pmod{m_2}$  are solvable only when  $n_1 = n_2 \pmod{\gcd(m_1, m_2)}$ .
- The solution is unique modulo  $\text{lcm}(m_1, m_2)$

## Example

- Solve:
  - $p1: x = 2 \pmod 3$
  - $p2: x = 3 \pmod 5$
  - $p3: x = 2 \pmod 7$
- From  $p1$ ,  $x = 3t + 2$ , for some integer  $t$ .
- Substituting this into  $p2$  gives  $3t = 1 \pmod 5$
- Same as  $p4$ :  $t = 2 \pmod 5$ 
  - {Implies  $3t = 6 \pmod 5 \rightarrow 3t = 1 \pmod 5$ }
  - Let  $t = 2 + 5s$
- Substitution into  $x = 3t + 2$  yields  $x = 15s + 8$

### Note:

$$\gcd(3, 5) = \gcd(5, 7) = \gcd(3, 7) = 1$$

### Continuing the example ...

- Substituting in p3:  $15s + 8 = 2 \pmod{7}$
- Divide out by 7 gives  $s = 1 \pmod{7}$   
 $[(2 \cdot 7 + 1)s + (7 + 1) = 2 \pmod{7}]$
- So  $s = 7u + 1$
- Hence  $x = 105u + 23$

### Proof of the Chinese Remainder Theorem

#### Forward Direction:

- The first congruence gives  $x = tm_1 + n_1$
- The second gives  $x = sm_2 + n_2$
- So we get  $tm_1 - sm_2 = n_2 - n_1$  (\*)  
 – Left side divisible by  $\gcd(m_1, m_2)$ . Hence right side divisible by  $\gcd(m_1, m_2)$ .

#### Backward Direction:

- Now suppose  $n_0 = (n_2 - n_1) / \gcd(m_1, m_2)$
- Then the last equation (\*) divided by  $\gcd(m_1, m_2)$  becomes:

$$t(m_1 / \gcd(m_1, m_2)) - s(m_2 / \gcd(m_1, m_2)) = n_0$$

### Proof Continued

- Implying  
 $t(m_1 / \gcd(m_1, m_2)) = n_0 \pmod{m_2 / \gcd(m_1, m_2)}$
- But  $m_1 / \gcd(m_1, m_2)$  and  $m_2 / \gcd(m_1, m_2)$  are relatively prime.
- Therefore, when  $n_0, m_1, m_2$  are given, we can find  $t$   
 Uses the fact that  $Ax = B \pmod{C}$  is solvable if  $A$  and  $C$  are relatively prime
- From  $t$ , we can find  $n$

### To prove the uniqueness ..

- assume  $n$  and  $N$  satisfy the two congruences. the differences give  
 $N - n = 0 \pmod{m_1}$  and  $N - n = 0 \pmod{m_2}$
- Implying  $N - n = 0 \pmod{\text{lcm}(m_1, m_2)}$ .

End of proof

### $Z_n$ and $Z_n^*$

- $Z_n = \{0, 1, \dots, n-1\}$
- $Z_n^* = \{x \in Z_n \text{ and } x \text{ is relatively prime to } n\}$
- Example:  $Z_{10}^* = \{1, 3, 7, 9\}$

**Theorem:**  $Z_n^*$  is closed under multiplication

**Proof:** Assume  $a, b \in Z_n^*$ . Need to show  $a \cdot b \in Z_n^*$

$$Ua + Vn = 1 \text{ -----(1)}$$

$$Xb + Yn = 1 \text{ -----(2)}$$

Multiply (1) and (2)

$$[Ua + Vn][Xb + Yn] = 1$$

$$UVab + [VXb + UYn + VYn]n = 1$$

### Euler's Totient Function

- Totient function  $\phi(n) = |Z_n^*|$ 
  - number of integers less than  $n$  and relatively prime to  $n$
  - If  $n$  is prime,  $\phi(n) = n - 1$
  - If  $n = p \cdot q$ , and  $p, q$  are primes,  $\phi(n) = (p - 1)(q - 1)$
  - If  $p$  is prime and  $k > 0$ ,  $\phi(p^k) = (p - 1)p^{k-1}$
- Examples:
  - $\phi(7) = 6$
  - $\phi(21) = \phi(3 \cdot 7) = 2 \cdot 6 = 12$

## Why is $\phi(n)=(p-1)(q-1)$ valid?

- Show:
  - $\gcd(m,pq)=1$  iff  $\gcd(m,p)=1$  and  $\gcd(m,q)=1$
  - $\Rightarrow$  obvious, because any factor of  $pq$  is a factor of  $p$  or a factor of  $q$
  - $\Leftarrow$  Suppose  $m_p \in \mathbb{Z}_p$  and  $m_q \in \mathbb{Z}_q$
  - Then  $U_p m_p + V_p p = 1$  and  $U_q m_q + V_q q = 1$ .
  - Let  $m_p = m - kp$  and  $m_q = m - lq$
  - Hence  $U_p m + (V_p - U_p k)p = 1$  and  $U_q m + (V_q - U_q l)q = 1$
  - Multiply and get  $[U_p U_q + **]m + [***]pq = 1$
  - So  $m_p \in \phi(p)$  and  $m_q \in \phi(q)$  iff  $m_p m_q \in \phi(pq)$

## Euler's Theorem

- For every  $a$  and  $n$  that are relatively prime,  $a^{\phi(n)} \equiv 1 \pmod n$ .
- Examples
  - $a=3, n=10, \phi(10)=\_\_\_\_\_\_, 3^{\phi(10)} \pmod{10} = \_\_\_\_\_\_$
  - $a=2, n=11, \phi(11)=\_\_\_\_\_\_, 2^{\phi(11)} \pmod{11} = \_\_\_\_\_\_$
- What if  $a$  and  $n$  that are **NOT** relatively prime?
- Generalization of Euler's Theorem
  - if  $n=pq$  ( $p, q$  are prime numbers)  $a^{\phi(n)+1} \equiv a \pmod n$  for all  $a$  in  $\mathbb{Z}_n$
  - $\phi(33) = \phi(3 \cdot 11) = 2 \cdot 10 = 20$
  - $101^{20} \pmod{33} = \_\_\_\_\_\_??$
  - Hint:  $101^{101} = 101^{2 \cdot \phi(33)+1} = 101 \pmod{33} = 2$

## Why is $a^{\phi(n)} \equiv 1 \pmod n$ valid?

- Let  $X$  be the product of all  $\phi(n)$  integers in  $\mathbb{Z}_n^*$
- Remember  $\mathbb{Z}_n^*$  is closed under multiplication
- Now multiply each elements of  $\mathbb{Z}_n^*$  by  $a$ .
- Now multiply all of them together.
- We get  $a^{\phi(n)} X$
- Multiplying all elements only rearranges them
- Hence the result is  $X$
- Hence  $a^{\phi(n)} X = X$

## Modular Exponentiation

- If  $x, n$  are relative primes, then
  - $x^y \pmod n = x^{y \pmod{\phi(n)}} \pmod n$
- if  $y \pmod{\phi(n)} = 1$  and  $x$  is relative prime with  $n$ , then  $x^y \pmod n = x \pmod n$
- Example:
  - $2^{101} \pmod{33} = 2^{101 \pmod{\phi(33)}} \pmod{33} = 2^2 \pmod{33} = 4$

## The Power of An Integer Modulo $n$

- Given  $a, n > 0$ , want to see if there exist  $m > 0$  such that
- $a^m \equiv 1 \pmod n$
- If  $a$  and  $n$  are relatively prime, then there is at least one integer  $m$  that satisfies the above equation.
  - That is, the Euler's totient function  $\phi(n)$ .
  - But  $\phi(n)$  may be not the smallest!
  - The least positive exponent  $m$  for which the above equation holds is referred to as:
    - The order of  $a \pmod n$
    - The exponent to which  $a$  belongs  $\pmod n$
    - The length of the period generated by  $a$ .

## Understanding The Order of $a \pmod n$

- Powers of Integers Modulo 19

$a$	$a^2$	$a^3$	$a^4$	$a^5$	$a^6$	$a^7$	$a^8$	$a^9$	$a^{10}$	$a^{11}$	$a^{12}$	$a^{13}$	$a^{14}$	$a^{15}$	$a^{16}$	$a^{17}$	$a^{18}$
1	1	1	1	1	1	1	1	1	1	1	1	1	1	1	1	1	1
2	4	8	16	13	7	14	9	18	17	15	11	3	6	12	5	10	1
4	16	7	9	17	11	6	5	1	4	16	7	9	17	11	6	5	1
7	11	1	7	11	1	7	11	1	7	11	1	7	11	1	7	11	1
8	7	18	11	12	1	8	7	18	11	12	1	8	7	18	11	12	1
9	5	7	6	16	11	4	17	1	9	5	7	6	16	11	4	17	1
18	1	18	1	18	1	18	1	18	1	18	1	18	1	18	1	18	1

## Observations in The Previous Table

- All sequences end in 1.
- The length of a sequence divides  $\phi(19) = 18$ .
  - Lengths: 1, 2, 3, 6, 9, 18.
- Some of the sequences are of length 18.
  - The base integer  $a$  generates (via powers) all nonzero integers modulo 19 (with different order)

## Primitive Root

- The highest possible order of  $a \pmod{n}$  is  $\phi(n)$ .
- **Primitive root:** If the order of  $a \pmod{n}$  is  $\phi(n)$ , then  $a$  is referred to as a **primitive root** of  $n$ .
  - The powers of  $a$ :  $a, a^2, \dots, a^{n-1}$  are distinct  $\pmod{n}$  and are all relatively prime to  $n$ .
- For a prime number  $p$ , if  $a$  is a primitive root of  $p$ , then  $a, a^2, \dots, a^{p-1}$  are all the distinct numbers mod  $p$ .

## Discrete Logarithm

- Given a primitive root  $a$  for a prime number  $p$ :
  - The expression  $b \equiv a^i \pmod{p}$ ,  $0 \leq i < (p-1)$ , produces the integers from 1 to  $(p-1)$ .
- The exponent  $i$  is referred to as **the index of  $b$  for the base  $a \pmod{p}$** , denoted as  $\text{ind}_{a,p}(b)$ .
  - Inverse of exponentiation = logarithm
- Some properties:
  - $\text{ind}_{a,p}(1) = 0$ , because  $a^0 \pmod{p} = 1$ .
  - $\text{ind}_{a,p}(a) = 1$ , because  $a^1 \pmod{p} = a$ .

## Discrete Logarithm

- Example:
  - Integer 2 is a primitive root of prime number 19

Number	1	2	3	4	5	6	7	8	9
Index	0	1	13	2	16	14	6	3	8
Number	10	11	12	13	14	15	16	17	18
Index	17	12	15	5	7	11	4	10	9

## Discrete Logarithm (Cont'd)

- Consider  $x = a^{\text{ind}_{a,p}(x)} \pmod{p}$ ,  $y = a^{\text{ind}_{a,p}(y)} \pmod{p}$ , and  $xy = a^{\text{ind}_{a,p}(xy)} \pmod{p}$ .
  - $a^{\text{ind}_{a,p}(xy)} \pmod{p} = (a^{\text{ind}_{a,p}(x)} \pmod{p})(a^{\text{ind}_{a,p}(y)} \pmod{p})$
  - $a^{\text{ind}_{a,p}(xy)} \pmod{p} = (a^{\text{ind}_{a,p}(x) + \text{ind}_{a,p}(y)}) \pmod{p}$
- By Euler's theorem:  $a^z \equiv a^q \pmod{p}$  iff  $z \equiv q \pmod{\phi(p)}$ .
  - $\text{ind}_{a,p}(xy) = \text{ind}_{a,p}(x) + \text{ind}_{a,p}(y) \pmod{\phi(p)}$ .
  - $\text{ind}_{a,p}(x^r) = [r \cdot \text{ind}_{a,p}(x)] \pmod{\phi(p)}$ .
- Discrete logarithm mod  $p$ : index mod  $p$ .
- **Computing a discrete logarithm mod a large prime number  $p$  is in general difficult**
  - Used as the basis of some public key cryptosystems.

## Hash Function

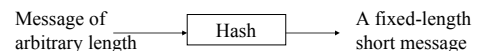

- Also known as
  - Message digest
  - One-way transformation
  - One-way function
  - Hash
- Length of  $H(m)$  much shorter than length of  $m$
- Usually fixed lengths: 128 or 160 bits

## Requirements for a Hash Function

- Consider a hash function  $H$ 
  - **Flexibility:** Can be applied to a block of data of any size
  - **Convenience (for check):** produce a fixed-length short output.
  - **Performance:** Easy to compute  $H(m)$
  - **One-way property:** Given  $H(m)$  but not  $m$ , it's difficult to find  $m$
  - **Weak collision resistance (free):** Given  $H(m)$ , it's difficult to find  $m'$  such that  $H(m') = H(m)$ .
  - **Strong collision resistance (free):** Computationally infeasible to find  $m_1, m_2$  such that  $H(m_1) = H(m_2)$

## Birthday Paradox

- Question:
  - What is the minimum value of  $k$  such that the probability of **at least two people in a group of  $k$  people have the same birthday** is greater than 0.5 that?
    - Ignore the leap years and assume each birthday is equally likely.
- Probability of  $k$  people having  $k$  different birthdays:  $Q(365, k) = {}^n C_k (1/365)^k = 365! / (365-k)! 365^k$
- Probability that at least two people have the same birthday:  $P(365, k) = 1 - Q(365, k) > 0.5$  yields the integer solution to the equation  $365! / (365-k)! 365^k > 0.5$
- $K$  is about 23.

## Generalization of Birthday Paradox

- Given a random variable that is an integer with uniform distribution between 1 and  $n$  and a selection of  $k$  instances of the random variables, what is the least value of  $k$  such that the probability  $P(n, k)$  is greater than 0.5 that there is at least one duplicate?
  - $P(n, k) > 1 - e^{-k(k-1)/2n}$
  - For large  $n$  and  $k$ , we have  $k = \sqrt{2(\ln 2)n} = 1.18\sqrt{n} \approx \sqrt{n}$
  - Intuition: How many  $k$  do we need to have a collision with  $P=0.5$ ?
- Implication
  - For a hash function  $H$  with  $2^m$  possible outputs, if we apply  $H$  to  $k=(2^m)^{1/2}=2^{m/2}$  random inputs, the probability that there is at least one duplicate is greater than 0.5.

## Birthday Attack

- **Objective= Find a fraudulent message with the same digest as a genuine message**
- The source, A, is prepared to sign a message
- The opponent generates  $2^{m/2}$  variations of the message, and prepares  $2^{m/2}$  variations on the fraudulent message.
- The opponent compares the two sets of messages to find a pair of messages that produces the same hash value. The probability of success is greater than 0.5. The opponent repeats generating variations until a match is found.
- The opponent offers the valid variation to A for signature, but attaches the signature to the fraudulent variation.

## Birthday Attack (Cont'd)

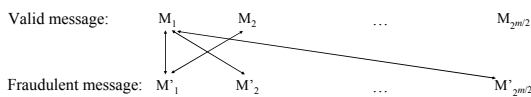

- Check to see if  $H(M_i) = H(M'_j)$ ?
- Send  $M_j$  to A to get his signature  $H(M_j)$
- Append  $H(M_j)$  to  $M'_j$  to get  $M'_j | H(M_j)$ , which appears a valid message with valid signature by A

## How Many Bits for Hash?

- $m$  bits, takes  $2^{m/2}$  to find two with the same hash
- 64 bits, takes  $2^{32}$  messages to search duplicate
- Need at least 128 bits

## Building Hash Using Cipher Block Chaining Techniques

- Use Block Cipher for Hashing
- Use Message Blocks as Keys to the Block Cipher
- Divide M into fixed-size blocks  $M_1, M_2, \dots, M_n$
- Compute the hash as follows
  - $H_0$ =Initial value
  - $H_i = E_{M_i}(H_{i-1})$
  - Hash value  $G = H_n$
- Weakness
  - Birthday attack (reason: hash value is too short)
  - Meet-in-the-middle attack

ISE at George Mason University

ISA 666 Duminda Wijesekera

43

## Building Hash Using Cipher Block Chaining Techniques (Cont'd)

- **Meet-in-the-middle attack**
  - Get the correct hash value G
  - Construct any message in the form  $Q_1, Q_2, \dots, Q_{n-2}$
  - Compute  $H_i = E_{Q_i}(H_{i-1})$  for  $1 \leq i \leq (n-2)$ .
  - Generate  $2^{m/2}$  random blocks; for each block X, compute  $E_X(H_{n-2})$ .
  - Generate  $2^{m/2}$  random blocks; for each block Y, compute  $D_Y(G)$ .
  - With high probability there will be an X and Y such that  $E_X(H_{n-2}) = D_Y(G)$ .
  - Form the message  $Q_1, Q_2, \dots, Q_{n-2}, X, Y$ . It has the hash value G.

ISE at George Mason University

ISA 666 Duminda Wijesekera

44

## Modern Hash Functions

- MD2, MD4, MD5
  - Developed by Ron Rivest on 1989, 1990 and 1991 respectively.
  - Specified in RFCs 1319 - 1321
  - Take arbitrarily long message, and generate 128-bit digest
  - MD2, MD4 have known weakness, and are considered broken
- SHA (Secure Hash Algorithm), SHA-1
  - Developed by NIST, very similar to MD4
  - SHA-1 was a revision to SHA that was published in 1994
  - Take up to  $2^{64}$  bit message, and generate 160-bit digest
- HMAC
- RIPEMD-160

ISE at George Mason University

ISA 666 Duminda Wijesekera

45

## MD5: Message Digest Version 5

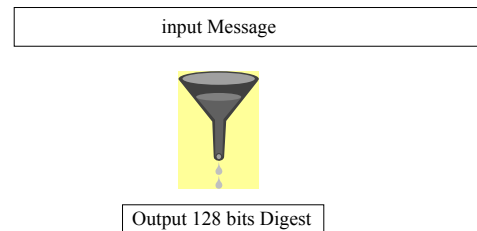

ISE at George Mason University

ISA 666 Duminda Wijesekera

46

## MD5: A High-Level View

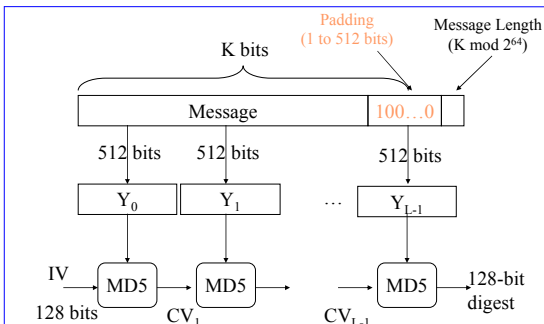

ISE at George Mason University

ISA 666 Duminda Wijesekera

47

## Padding

- Given original message M, add padding bits "10\*" such that resulting length is 64 bits less than a multiple of 512 bits.
- Append (the length of the original message in bits mod  $2^{64}$ ), represented in 64 bits to the padded message
- Final message is chopped 512 bits a block
- Exercise:
  - How to add padding bits to a message that is already a multiple of 512 bits?

ISE at George Mason University

ISA 666 Duminda Wijesekera

48

## MD5 (Intermediate) Buffer

- Used to hold intermediate and final result of MD5.
- 128 bits
- Represented as four 32-bit words
  - (A,B,C,D)
  - Initially, A=0x67452301, B=0xEFCDAB89, C=0x98BADCFE, D=0x10325476
  - Stored in little-endian format:
    - A=0x01234567
    - B=0x89ABCDEF
    - C=0xFEDCBA98
    - D=0x76543210.

## Processing of A Single Block

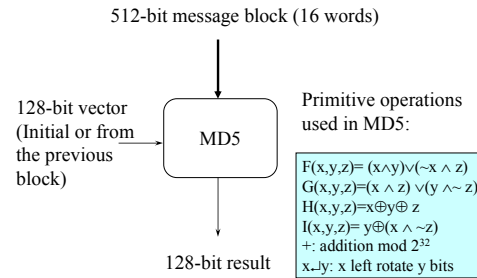

## Processing of A Single Block (Cont'd)

- Every message block contains **16 32-bit words**:
  - $X[0] X[1] X[2] \dots X[15]$
- Every stage consists of **4 rounds** over the message block, each modifying the MD5 buffer (A,B,C,D).
  - The four rounds use functions F, G, H, I, respectively.
- Each round uses one-fourth of a 64-element table  $T[1..64]$ .
  - $T[i] = 2^{32} * \text{abs}(\sin(i))$  represented in 32 bits.
- The output of the fourth round is added to the input to the first round.

## Processing of Block $m_i$ : 4 Rounds

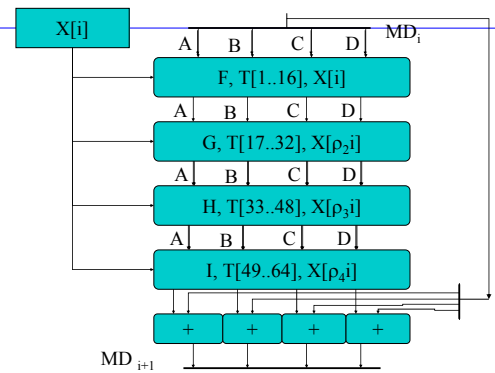

## Logic of Each Round

- Each round consists of 16 steps
- Each step is of the form
  - $A \leftarrow B + ((A + g(B,C,D) + X[k] + T[i]) \lll s)$ 
    - Function g is one of F, G, H, I
    - $X[k]$  is the word in the input
    - $T[i]$  is the  $i^{\text{th}}$  word in T
    - $\lll s$ : circular left shift by s bits.
  - Followed by a word level circular right shift of one word.

## Logic of Each Step

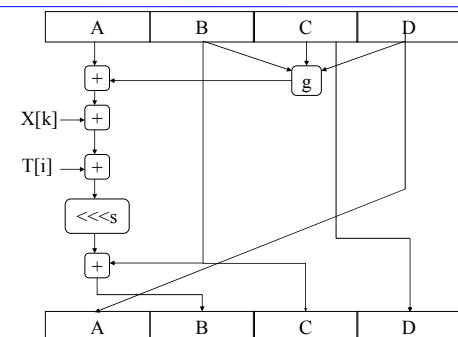

## Logic of Each Step

- Within a round, each of the 16 words of  $X[i]$  is used exactly
  - First round,  $X[i]$  are used in the order of 1
  - Round 2, in the order of  $\rho_2(i)$ , where  $\rho_2(i)=(1+5i)\bmod 16$ ;
  - Round 3, in the order of  $\rho_3(i)$ , where  $\rho_3(i)=(5+3i)\bmod 16$ ;
  - Round 4, in the order of  $\rho_4(i)$ , where  $\rho_4(i)=7i\bmod 16$ ;
- Each word of  $T[i]$  is used exactly once.

## Security of MD5

- No known method that breaks MD5 (till 08/2004).
- However, there are methods that are close to breaking MD5
  - Technique that enables the generation of a collision for a single 512-bit block.
- Birthday attack
  - $2^{64}$

## Latest Result on Collision of MD5, SHA

- In Crypto'2004,
  - Chinese researchers reported a family of collisions in MD5 (after fixing the previous bug in their analysis), and also reported that their method can efficiently ( $2^{40}$  hash steps) find a collision in SHA-0. Paper is available at <http://eprint.iacr.org/2004/199/>
  - Eli Biham announced new results in finding collision in a reduced-round version of SHA-1. The full SHA-1 algorithm does 80 rounds of scrambling. At present, Biham and Chen can break versions of SHA-1 that use up to about 40 rounds
- MD5 is fatally wounded! its use will be phased out soon.
- SHA-1 is still alive, NIST plans to phase out SHA-1 by 2010
  - brief is at [http://csrc.nist.gov/hash\\_standards\\_comments.pdf](http://csrc.nist.gov/hash_standards_comments.pdf)